

**WMS**  
2017  
Woodworking Machinery & Supply  
Conference and Expo

November 2-4, 2017  
International Centre  
Toronto, Canada

The National Event for Canada's Wood Industry

# WINNING TECHNOLOGY & SUPPLIES

A QUICK SURVEY DRAWN 2017 SHOW FLOOR



**WMS**  
2017  
Woodworking Machinery & Supply  
Conference and Expo



November 2-4, 2017  
International Centre  
Toronto, Canada



The National Event for Canada's Wood Industry

# WINNING TECHNOLOGY & SUPPLIES

THE NATIONAL EVENT FOR CANADA'S WOOD INDUSTRY BRINGS AWARD  
WINNING SUPPLIERS FROM AROUND THE WORLD TO YOUR DOOR

# WINNING TECHNOLOGY & SUPPLIES

SURVEY SOURCES INCLUDE:





## **SALICE AIR –**

**WMS BOOTH # 1149** SALICE S.P.A., NOVEDRATE, ITALY  
IN-HOUSE DESIGN ROSS DESIGN GMBH, KEHL, GERMANY  
[WWW.SALICECANADA.COM](http://WWW.SALICECANADA.COM)

THE HINGE AIR IS COMPACT AND UNDERSTATED DESIGN. THANKS TO A SOPHISTICATED TECHNOLOGY, IT AFFIXES THE ROTATING DOORS TO THE UPPER OR LOWER BASE OF THE FURNITURE WITHOUT THE NEED FOR ATTACHING TO THE SIDES OF THE FURNITURE. AIR MEETS ALL OF THE TECHNICAL REQUIREMENTS FOR A HINGE – FROM THREE-DIMENSIONAL ADJUSTMENT TO A SOFT CLOSE AND A PUSH-TO-OPEN FUNCTION.

**VISIONARY, CHALLENGER, BEST OF INTERZUM**



## **IRIDIA BIO** WATERBASED COATINGS

WMS BOOTH #1065

ICA GROUP, CIVITANOVA MARCHE, ITALY

IN-HOUSE DESIGN LORENZO PANICCIA

[WWW.ICAAMERICA.BIZ](http://WWW.ICAAMERICA.BIZ)

IRIDEA BIO IS A WATER-BASED LINE OF COATINGS FOR INTERIORS. MANUFACTURED FROM PLANT-BASED WASTE SUBSTANCES USING INNOVATIVE PROCESSES, THEY ARE RESILIENT, RESISTANT TO CHEMICALS AND LIGHTFAST. THE COMBINATION OF ACRYLIC-BASED RESINS OBTAINED FROM RENEWABLE SOURCES MEANS THAT THEY DRY FAST, ARE HARD AND RESISTANT TO YELLOWING. AS SINGLE OR TWO-COMPONENT COATINGS, THEY ARE ALSO SIMPLE TO SAND, AND ARE SUITED TO INDUSTRIAL PROCESSING.

**INTERZUM HIGH PRODUCT QUALITY**

WMS WINNING TECHNOLOGY & SUPPLIES

**WMS**  
2017  
Woodworking Machinery & Supply  
Conference and Expo

November 2-4, 2017  
International Centre  
Toronto, Canada

The National Event for Canada's Wood Industry



## **ARPA**– LOSA HPL FINISH

**WMS BOOTH # 1526** ARPA INDUSTRIALE, BRA, ITALY  
IN-HOUSE DESIGN ARPALAB (FAUSTO DONATO, FILIPPO MANETTI, SANDRO MARINI)

[WWW.ARPAINDUSTRIALE.COM](http://WWW.ARPAINDUSTRIALE.COM)

THE LOSA FINISH FOR HIGH-QUALITY HPL PANELS WAS DESIGNED TO REVISIT THE LOOK AND FEEL OF SHALE. IT REINTERPRETS THE SHALE SURFACES VERY NATURALLY, WITH AN IMPRESSIVE THREE-DIMENSIONAL EFFECT. THE SURFACE STRUCTURE REFLECTS A CUT IN THE 60-DEGREE ANGLE THROUGH THE STONE. LOSA IS AVAILABLE IN VARIOUS DESIGNS CREATED TO ENHANCE THE PERCEPTION OF DEPTH.

**INTERZUM HIGH PRODUCT QUALITY**



## **LEGRABOX** DESIGN OPTIONS BOX SYSTEM

**WMS BOOTH # 1115**

JULIUS BLUM GMBH, HÖCHST, AUSTRIA IN-HOUSE DESIGN

[WWW.BLUM.COM](http://WWW.BLUM.COM)

THE LEGRABOX DESIGN OPTIONS USE THE DOUBLE-SKIN FRAMES TO FACILITATE DIFFERENT DESIGNS FOR THE OUTSIDES AND INSIDES OF PULL-OUTS AND DRAWERS. THE LARGE SELECTION OF COLOURS AND MATERIALS ALLOWS A WIDE RANGE OF COMBINATIONS, FOR EXAMPLE “TERRA BLACK MATT” ON THE INSIDE AND HIGH-QUALITY ANTI-FINGERPRINT STAINLESS STEEL ON THE OUTSIDE. IN ADDITION, THE NEW FRAME DESIGN DISPENSES WITH THE LOWER ACCENT LINE, THUS ALLOWING FOR A CUSTOMISED FRAME WITH A PRINTED LOGO..

**INTERZUM HIGH PRODUCT QUALITY**

WMS WINNING TECHNOLOGY & SUPPLIES





Bayreuth

## **RAUVISIO** – CRYSTAL MIRROR

SURFACE MATERIAL REHAU AG + CO, REHAU, GERMANY

**WMS BOOTH # 1080**

IN-HOUSE DESIGN THORSTEN ENGELBRECHT, MATTHIAS HAASLER, RENÉ DE JONG, HANS PETER MEHNERT,  
ANNETT SCHULZ [HTTP://WWW.NA.REHAU.COM](http://www.na.rehau.com)

RAUVISIO CRYSTAL MIRROR IS A POLYMER MIRROR THAT CAN BE PROCESSED IN A VARIETY OF DIFFERENT WAYS THANKS TO ITS POLYMER PROPERTIES. THE REFLECTIVE SURFACE MATERIAL IS NOT ONLY LIGHTER AND MORE DURABLE THAN REAL GLASS, IT CAN ALSO BE CUT TO SIZE, IS BENDABLE AND CAN THUS BE MADE INTO VIRTUALLY ANY SHAPE. WALL MIRRORS, REFLECTIVE SURFACES ETC. CAN BE CREATED USING WOODWORKING TOOLS AND CLEANED EASILY THANKS TO A DIRT-RESISTANT COATING..

**INTERZUM HIGH PRODUCT QUALITY**

WMS WINNING TECHNOLOGY & SUPPLIES



**WMS**  
2017  
Woodworking Machinery & Supply  
Conference and Expo

November 2-4, 2017  
International Centre  
Toronto, Canada

The National Event for Canada's Wood Industry





## **DECOSPAN** – NØRDUS REAL WOOD VENEERED PANELS

**WMS BOOTH #1079** QUERKUS & SHINNOKI @ HARDWOOD INC.  
DECOSPAN NV, MENEN, BELGIUM  
IN-HOUSE DESIGN

[WWW.NORDUSDECOSPAN.COM](http://WWW.NORDUSDECOSPAN.COM)

NØRDUS IS A RANGE OF REAL WOOD VENEERED PANELS INSPIRED BY SCANDINAVIAN LIVING. THE COLLECTION COMPRISES EIGHT DESIGNS AND IS AVAILABLE AS VENEERED PANEL, FLEX AND MATCHING EDGE BANDS. FOR NØRDUS, ONLY THE BEST SOFTWOOD AND BIRCH WOOD IS COLLECTED AND CAREFULLY PROCESSED INTO VENEER USING RESOURCES SPARINGLY. THANKS TO THE INNOVATIVE MIXMATCH JOINING TECHNIQUE, THE VENEER PANELS GET A SOLID WOOD CHARACTER AND CAN BE PAINTED OR VARNISHED INDIVIDUALLY AFTERWARDS.

**INTERZUM HIGH PRODUCT QUALITY**

WMS WINNING TECHNOLOGY & SUPPLIES

**WMS**  
2017  
Woodworking Machinery & Supply  
Conference and Expo

November 2-4, 2017  
International Centre  
Toronto, Canada

The National Event for Canada's Wood Industry



**PERFECTSENSE**—HIGH-GLOSS AND MATT LACQUERED BOARDS  
FRITZ EGGER GMBH & CO. OG HOLZWERKSTOFFE, ST. JOHANN IN TIROL,  
AUSTRIA, IN-HOUSE DESIGN

**WMS BOOTH # 1039** – UPPER CANADA FOREST PRODUCTS  
[WWW.EGGER.COM](http://WWW.EGGER.COM)

PERFECTSENSE ARE HIGH-GLOSS AS WELL AS MATT, DECORATIVE LACQUERED BOARDS. PERFECTSENSE GLOSS IS CHARACTERISED BY ITS HIGH REFLECTIVE PROPERTIES AND REAL GLASS LOOK. PERFECTSENSE MATT ON THE OTHER HAND HAS A VELVETY FEEL AND ANTI-FINGERPRINT PROPERTIES.

**INTERZUM HIGH PRODUCT QUALITY**

WMS WINNING TECHNOLOGY & SUPPLIES

**WMS**  
2017  
Woodworking Machinery & Supply  
Conference and Expo

November 2-4, 2017  
International Centre  
Toronto, Canada

The National Event for Canada's Wood Industry

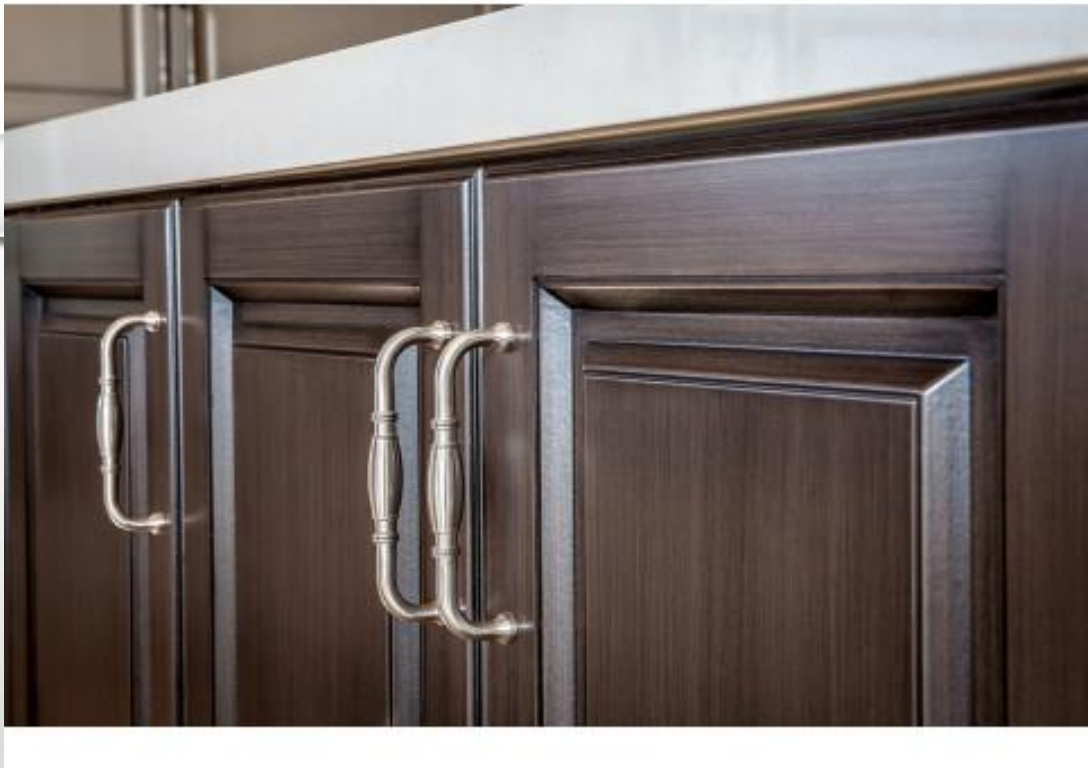

**KBIS** ORLANDO  
JANUARY 10-12  
2017

**FUSION FINISHES**—AN INNOVATION IN CABINETS THAT WAS CREATED IN HOUSE AT SUPERIOR CABINETS, OFFERS CUSTOMERS A DECORATIVE HAND-CRAFTED FINISH ON MDF, WITHOUT THE HIGH COST AND INFLEXIBILITY OF PAINTED WOOD CABINETS. FUSION CABINETS ARE ONE-PIECE DOORS MADE FROM MDF, STAINED AND FINISHED WITH A HANDCRAFTED CHALK TECHNIQUE TO GIVE AN AUTHENTIC REAL WOOD LOOK. FUSION COMPLETELY CHALLENGES THE MYTH THAT MDF IS ONLY WORTHY OF PAINTING AND ELEVATES THE FINISHING CAPABILITY, TRANSFORMING IT INTO SOMETHING TRULY AMAZING.

**BEST OF KBIS 2017 PEOPLE CHOICE**

WMS WINNING TECHNOLOGY & SUPPLIES



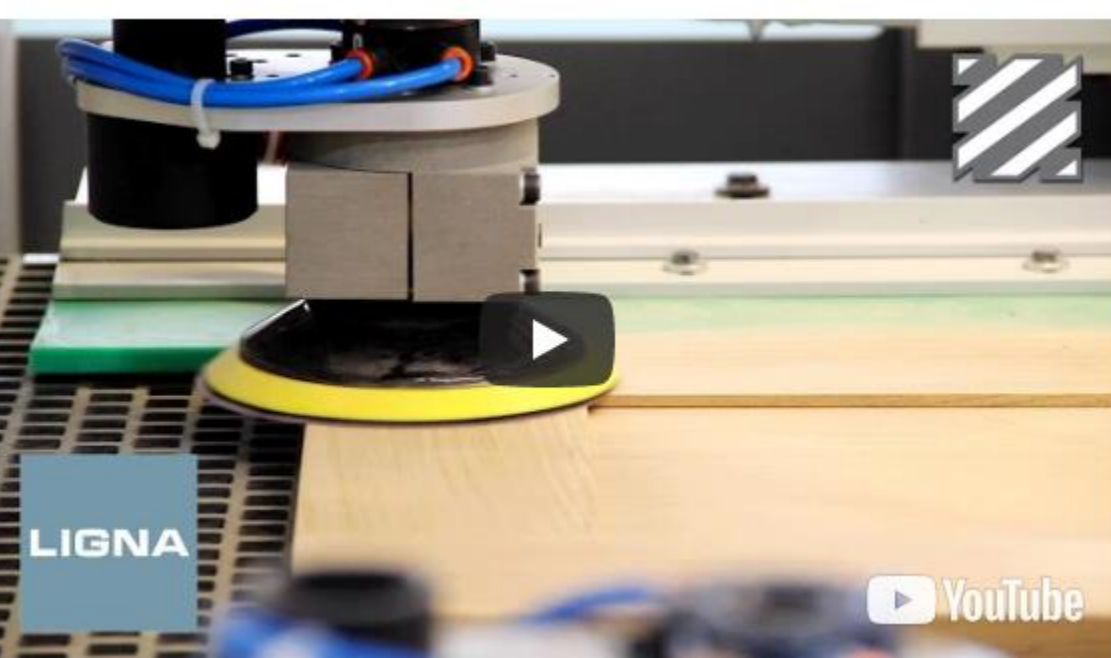

## VIET ROBOTIC SANDER—BIESSE WON FOR THE VIET

ROBOTIC SANDER FOR CROSS GRAIN SCRATCHING ON MDF, WOOD AND PAINTED DOORS. THE MACHINE ALLOWS FOR THE SANDING OF PANELS IN ANY DIRECTION AND ON DIFFERENT PLANES, AS WELL AS ON THE INSIDE OF PROFILES AND SHAPED EDGES.

**WMS 2017 BOOTH #1513**

[HTTPS://WWW.WOODWORKINGNETWORK.COM/IWF/IWF-PRODUCTS/BIESSES-ROBOTIC-SANDING-MACHINE-MAKES-IWF-CHALLENGERS-CUT](https://www.woodworkingnetwork.com/iwf/iwf-products/biesses-robotic-sanding-machine-makes-iwf-challengers-cut)

**IWF CHALLENGER AWARD 2016**

WMS WINNING TECHNOLOGY & SUPPLIES



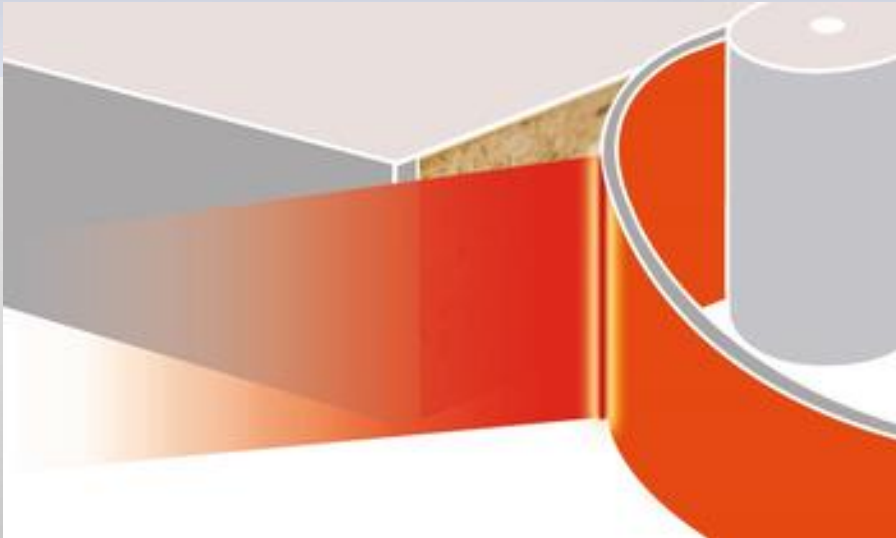
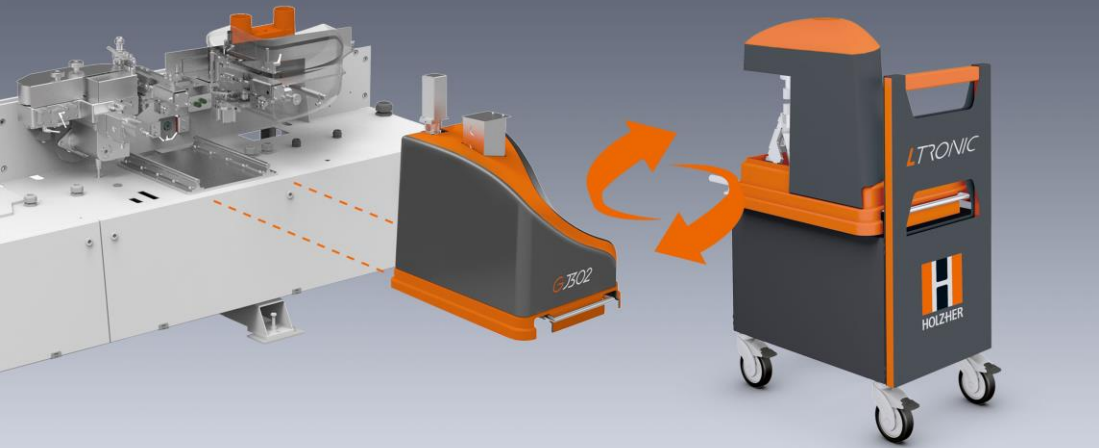

**LTRONIC EDGEBAND**—HOLZ-HER WON FOR ITS LTRONIC EDGEBANDING TECHNOLOGY. THE NEWLY DEVELOPED NIR MODULE (NIR = NEAR INFRARED RADIATION) IN THE LTRONIC UNIT IS ELECTRONICALLY CONTROLLED FOR ACTIVATING THE LASER EDGING FUNCTIONAL LAYER. LTRONIC IS READY FOR OPERATION AT THE TOUCH OF A BUTTON AND OPERATES WITHOUT ANY AIR BLAST NOISE OR COMPRESSED AIR.

**WMS 2017 BOOTH #2605 (TAURUS CRACO)**

**IWF CHALLENGER AWARD 2016**

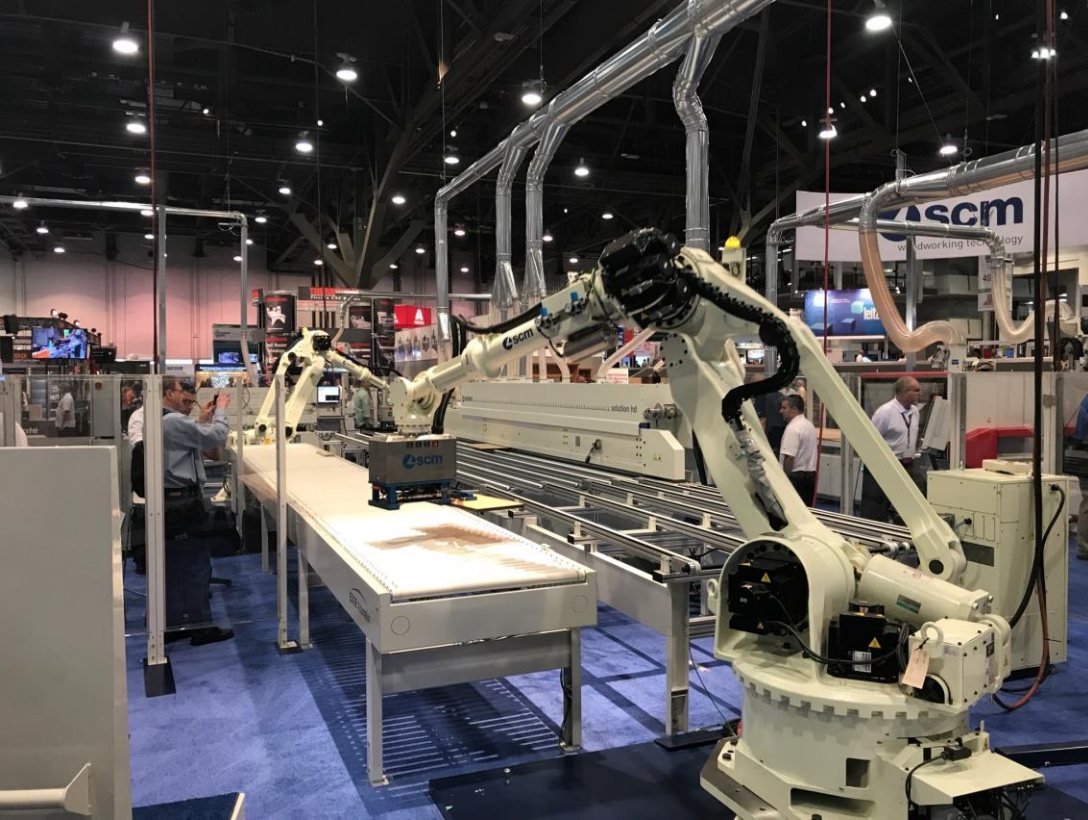

AWFS  
*Visionary*  
Awards

## SCM LEAN ROBOTIC CELL-

WMS 2017 BOOTH #  
SCM'S LEAN ROBOT CELL'S RAPID CASE DESIGN, MACHINING AND ASSEMBLY IS  
NOW A POSSIBILITY NOT ONLY IN THE DESIGN AND CAD SOFTWARE, BUT FOR  
MANUFACTURING THROUGH ROBOTIC AUTOMATION.

**WMS 2017 BOOTH #2627, 2643**

**AWFS VISIONARY AWARD 2017**

WMS WINNING TECHNOLOGY & SUPPLIES

**WMS**  
2017  
Woodworking Machinery & Supply  
Conference and Expo

November 2-4, 2017  
International Centre  
Toronto, Canada

The National Event for Canada's Wood Industry

## LASER PRODUCTS TEMPLATER-

LT-2D3D LASER TEMPLATER MEASURES AN AREA, THEN EXPORTS DIRECTLY TO CABINET VISION, 2020, MICROVELLUM, AND PRO KITCHEN DESIGN APPLICATIONS. IT INTERFACES TO THE MICROSOFT SURFACE LAPTOP.

**WMS 2017 BOOTH #2136**  
**[HTTP://LASERPRODUCTSUS.COM](http://LASERPRODUCTSUS.COM)**

**AWFS VISIONARY AWARD 2017**

# & DOZENS MORE AMONG NOMINEES

